

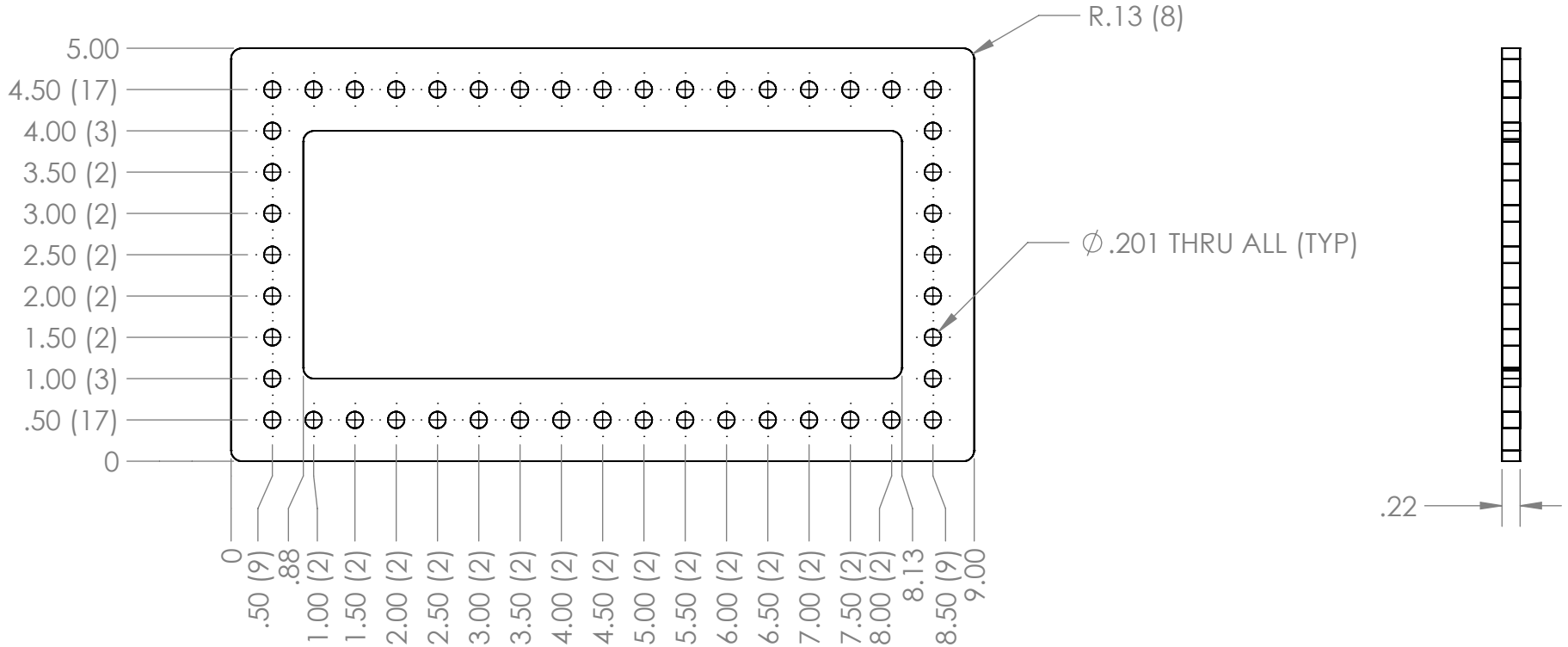

REVISION HISTORY			
REV.	DESCRIPTION	DATE	DRAWN BY
1	ORIGINAL PRINT	7/3/2025	A. GUPTA

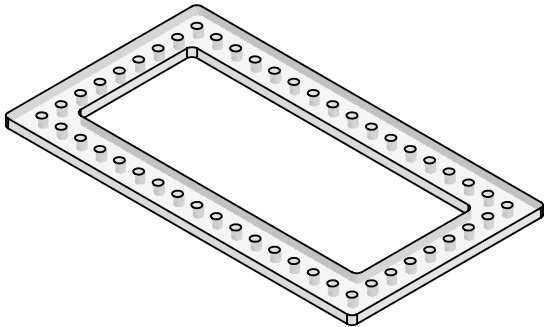

*** SEE CAD FOR ADDITIONAL TOOLPATH INFO***



UNLESS OTHERWISE SPECIFIED:		COMMENTS:				
DIMENSIONS ARE IN INCHES		DUAL DIMENSIONS ARE IN MILLIMETERS.				
TOLERANCES: FRACTIONAL ±1/16 ANGULAR: MACH ±1° ANGULAR: BEND ±5° ONE PLACE DECIMAL ±0.1 TWO PLACE DECIMAL ±0.01 THREE PLACE DECIMAL ±0.005 FOUR PLACE DECIMAL ±0.0005		BREAK ALL SHARP EDGES		TITLE: ROBOT CART BATTERY PLATE		
MATERIAL rm-0031a CLEAR PC		NAME	DATE	SIZE	DWG. NO.	REV
FINISH DEBURRED		CHECKED	PY	A	am-5677	1
DO NOT SCALE DRAWING		ENG APPR.		SCALE: 1:2		WEIGHT:
		MFG APPR.		SHEET 1 OF 1		
		Q.A.				